

CasaTunes CT-250A
2 x 50W Stereo Amplifier

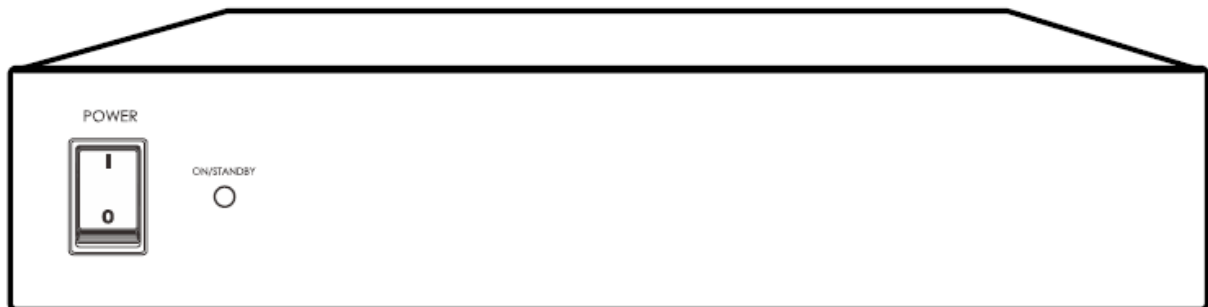

User's Manual

CONTENTS

SAFETY WARNINGS AND GUIDELINES	3
INTRODUCTION	4
FEATURES.....	4
PACKAGE CONTENTS.....	6
PRODUCT OVERVIEW.....	7
Front Panel.....	7
Rear Panel.....	7
THERMAL PROTECTION	8
SHORT CIRCUIT PROTECTION.....	9
MOUNTING OPTIONS	10
Stand-Alone Setup	10
Single Rack-Mount Setup.....	10
Dual Rack-Mount Setup.....	12
STEREO INSTALLATION.....	12
MONO BRIDGED INSTALLATION	16
SPECIFICATIONS.....	19
REGULATORY COMPLIANCE	20
Notice for FCC	20
Notice for Industry Canada	20

SAFETY WARNINGS AND GUIDELINES

Please read this entire manual before using this device, paying extra attention to these safety warnings and guidelines. Please keep this manual in a safe place for future reference.

- This device is intended for indoor use only.
- Do not expose this device to water or moisture of any kind. Do not place drinks or other containers with moisture on or near the device. If moisture does get in or on the device, immediately unplug it from the power outlet and allow it to fully dry before reapplying power.
- Do not touch the device, the power cord, or any other connected cables with wet hands.
- This device uses a grounded power cord and requires a ground connection for safe operation. Ensure that the power source has a proper ground connection. Do not modify the plug or use a "cheater" plug to bypass the ground connection.
- Do not expose this device to excessively high temperatures. Do not place it in, on, or near heat sources, such as a fireplace, stove, radiator, etc. Do not leave it in direct sunlight.
- This device ventilates excessive heat through the slots and openings in the case. Do not block or cover these openings. Ensure that the device is in an open area where it can get sufficient airflow to keep from overheating.
- Prior to operation, check the unit and power cord for physical damage. Do not use if physical damage has occurred.
- Take care to prevent damage to the power cord. Do not allow it to become crimped, pinched, walked on, or become tangled with other cords. Ensure that the power cord does not present a tripping hazard.

- Never unplug the unit by pulling on the power cord. Always grasp the connector head or adapter body.
- Ensure that power is turned off and disconnected before making any electrical connections.
- Clean using a soft, dry cloth only. Do not use chemical cleaners, solvents, or detergents. For stubborn deposits, moisten the cloth with warm water.
- This device has no user serviceable parts. Do not attempt to open, service, or modify this device.

INTRODUCTION

Thank you for purchasing the CasaTunes CT-250A Amplifier. This 2-channel class D power amplifier features a stereo speaker output, with support for 4-ohm and 8-ohm speakers. It can deliver 50 watts per channel into 8-ohm loads or 65 watts per channel into 4-ohm loads. Additionally, the output can be bridged to provide 120 watts to a single 8-ohm speaker. It includes a buffered loop line output of the original signal for driving another power amplifier in distributed whole house audio systems. The amp can be configured for always on, signal detection, or triggered power on status. It also includes a 12-volt trigger output for controlling other devices.

FEATURES

- Class-D amplifier providing 50 watts/channel (RMS) into 8 ohm loads or 65 watts/channel into 4-ohm loads
- Bridgeable output provides 120 watts into a single 8-ohm load
- 4-pole detachable speaker screw connector (Phoenix connector) with support for up to 12 AWG speaker wire

- 12-volt trigger input for power-on/off
- 12-volt trigger output for controlling other devices
- Buffered loop output of original signal for connecting additional amplifiers
- Rear panel volume gain adjustment
- Built-in thermal and short circuit protection circuits
- Includes rack-mount ears

PACKAGE CONTENTS

Please take an inventory of the package contents to ensure you have all the items listed below. If anything is missing or damaged, please contact CasaTunes Customer Service for a replacement.

- 1x 100-watt stereo power amplifier
- 1x AC power cord (NEMA 5-15 to IEC 60320 C13)
- 1x Power cord anchor
- 1x Trigger cable
- 2x Short rack-mount ears
- 1x Long rack-mount ear
- 1x Bridge plate
- 6x Button head screws
- 4x Countersunk screws
- 4x Rubber feet
- 1x User's manual

PRODUCT OVERVIEW

Front Panel

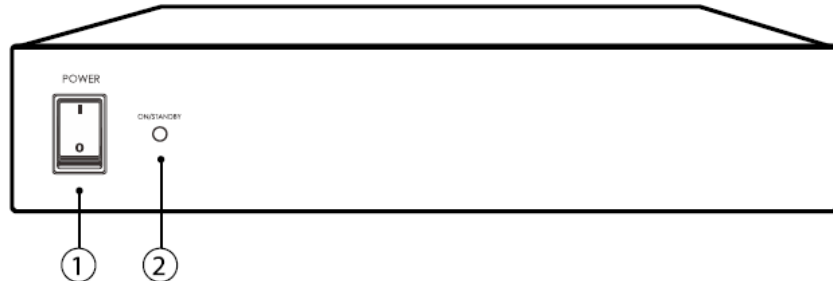

1. **Power Switch:** Turns the amplifier on and off.
2. **Power LED:** Illuminates amber on initial power-up, then glows either green during normal operation or red when in standby mode.

Rear Panel

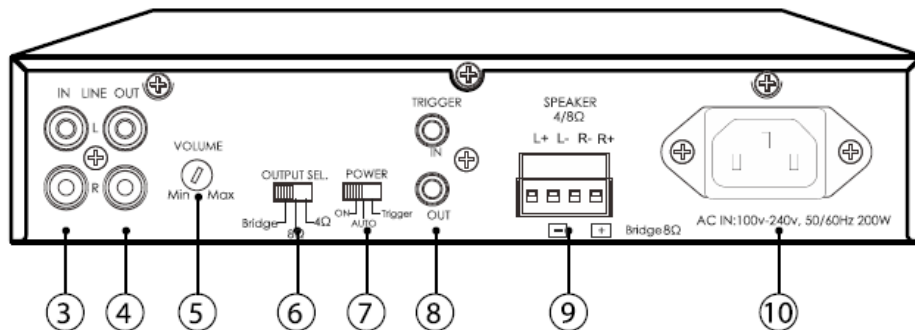

3. **Line In:** Stereo line-level analog RCA input jacks. When using bridged mode, the mono input should be connected to the L input.
4. **Line Out:** Stereo, buffered, loop line output of the original signal for connecting additional amplifiers.
5. **Volume:** Gain control to limit the maximum volume level.
6. **Output Selection:** Switch to configure the type of output. When in the Bridged position, the amplifier can be bridged for more power into a

single 8-ohm load. The 8-ohm and 4-ohm positions optimize the stereo output for 8- or 4-ohm loads.

7. **Power Selection:** Switch to control the power-on behavior of the amplifier. When in the On position, the amplifier is always on whenever the **Power Switch (1)** is in the On position. When set to **Auto**, the amplifier will automatically go into standby mode when no audio signal is detected and will power on when an audio signal is detected. When set to the **Trigger** position, the amplifier will power on or off whenever a 12-volt trigger is applied to the **Trigger In (8)**. When set to the **Auto** or **Trigger** positions, the **Power Switch (1)** on the front panel should be left in the **On** position.
8. **Trigger:** 3.5mm jacks for 12-volt Trigger In and Out. The Trigger In can turn the amplifier on or off and the Trigger Out can be used to control other devices.
9. **Speaker:** Removable Phoenix connector for attaching the speaker wires. When connecting a single speaker in bridged mode, the negative lead should be attached to **L-** and the positive lead to **R+**. It can accept speaker wire up to 12 AWG.
10. **AC IN:** IEC 60320 C14 panel connector for attaching the included power cord.

THERMAL PROTECTION

The amplifier monitors its temperature and will activate the thermal protection circuit if the temperature exceeds a safe limit. This can occur if the amp has been operated at high volumes for an extended period of time, if it has inadequate ventilation, or if the speaker load is below the minimum impedance of 4 ohms. The amp will shut down when the Thermal Protection circuit engages. You must turn off the amp's power switch and wait until the amp cools down, then power the amp back on.

SHORT CIRCUIT PROTECTION

If the amplifier detects a short circuit on one or both speaker outputs, the **Power LED (2)** will glow orange and output will be disabled. If this occurs, turn off the amplifier and check the speakers and speaker wires for a short circuit.

MOUNTING OPTIONS

This amplifier can be placed stand-alone on a flat surface, such as a table or shelf, or can be installed into a standard 19" equipment rack, either by itself or side-by-side with a second Unity power amp.

Stand-Alone Setup

To use the amplifier in a stand-alone installation, locate the included sheet with four rubber feet. Peel each rubber foot from the sheet and attach them to the bottom of the amp at each of the four corners. This will both protect your mounting surface from scratches and will prevent any incidental noise from vibration.

Single Rack-Mount Setup

Perform the following steps to install a single amplifier into a 19" equipment rack.

1. Using three of the button head screws, attach one short rack-mount ear to one side of the amplifier, with the flat side flush with the front panel.
2. Using the remaining three button head screws, attach the long rack-mount ear to the other side of the amplifier, with the long flat side flush with the front panel. It does not matter which side of the amp has the short rack-mount ear and which side has the long one.
3. Using rack-mount screws (not included), secure the two rack-mount ears to the rack mount.

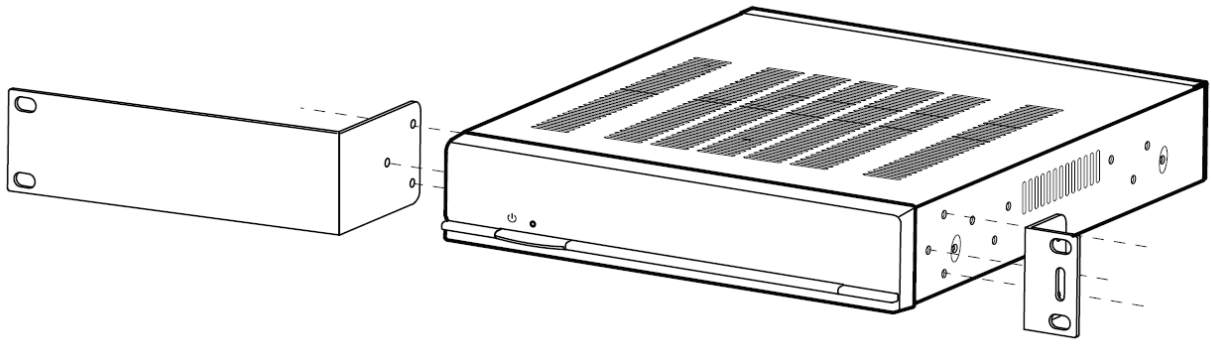

Dual Rack-Mount Setup

Perform the following steps to install two amplifiers side-by-side into a 19" equipment rack.

1. Turn the amplifiers over and place them side by side.
2. Place the bridge plate over the junction of the two amps with the beveled holes visible, then attach it to the two amps using the four countersunk screws.
3. Turn the amps over so they are right-side up, then attach one short rack-mount ear to the exposed side of each amp using three button head screws.
4. Using rack-mount screws (not included), secure the two rack-mount ears to the rack mount.

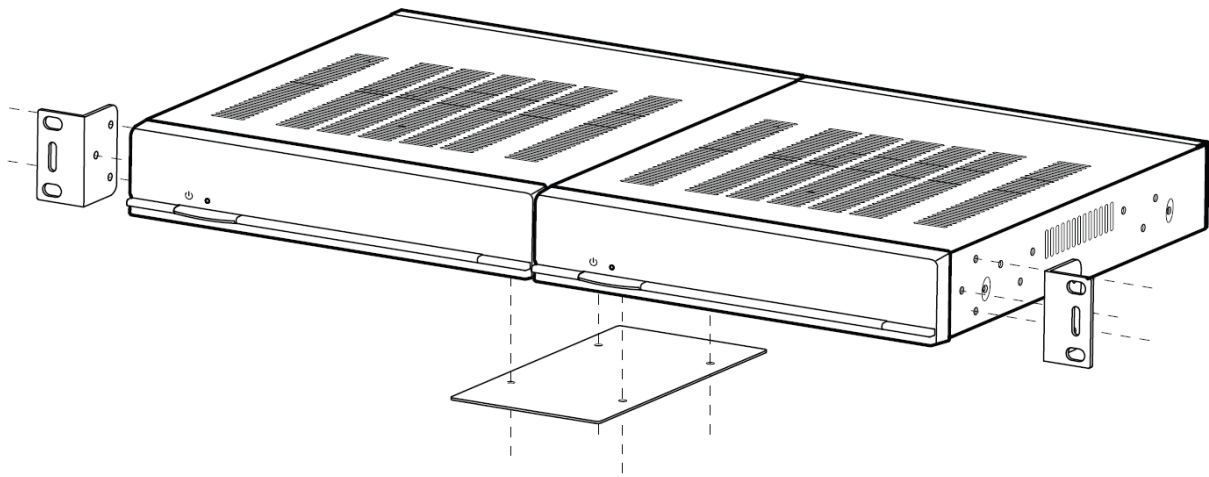

STEREO INSTALLATION

1. Ensure that all equipment to be connected is powered off and unplugged from its power source prior to making any electrical or audio connections.
2. Place the amplifier in its intended location.

3. Using a 1/8" flat head screwdriver, loosen the four screws on the **Speaker (9)** Phoenix connector to open the speaker wire clamps.
4. Using a two-conductor speaker wire (not included), insert the negative lead into the **L- connector**, then tighten the screw to lock it in place. Give the wire a gentle tug to ensure it is securely attached to the connector. Repeat for the positive lead and the **L+ connector**.
5. Connect the negative lead of the speaker wire to the negative input on your left channel speaker, then connect to the positive lead to the positive input.
6. Using a second two-conductor speaker wire, repeat steps 4 and 5 for the **R-** and **R+ connectors**, and the right channel speaker.
7. Using a stereo RCA cable (not included), plug the left and right plugs into the **L** and **R** connectors on the **Line In (3)**, then plug the other end into the analog stereo outputs on your preamplifier, television, or other audio source device.
8. (Optional) Using a stereo RCA cable (not included), plug one end into the inputs on a second amplifier, then plug the left and right plugs into the **L** and **R** connectors on the **Line Out (4)**.
9. (Optional) Using a 3.5mm cable (not included), plug one end into the **Trigger In (8)** jack, then plug the other end into the trigger output of your controller.
10. (Optional) Using a 3.5mm cable (not included), plug one end into the trigger input of a device you want to control using the amplifier, then plug the other end into the **Trigger Out (8)**.
11. If you connected 8-ohm speakers, set the **Output Selection (6)** switch to the 8 Ω position. If you connected 4-ohm speakers, set it to the 4 Ω position.
12. Set the **Power Selection (7)** switch to the **On**, **Auto**, or **Trigger** position, depending on how you want to control the amplifier's power-on behavior.

When set to **On**, the amplifier is always on whenever the **Power Switch (1)** is in the **On** position. When set to **Auto**, the amplifier will power on when an audio signal is detected and will power off after a few minutes without an audio signal on the input. When set to the **Trigger** position, the amplifier turns on and off when a 12-volt signal is detected on the **Trigger In (8)**. When using the **Auto** or **Trigger** options, the **Power Switch (1)** on the front panel must be set to the **On** position.

13. Using a 1/8" flat head screwdriver, turn the **Volume (5)** control fully counterclockwise to the minimum position.
14. Ensure that the **Power Switch (1)** is in the **Off** position.
15. Plug the C13 connector on the included AC power cord into the C14 **Power In (10)** connector, then plug the other end into a nearby AC power outlet.
16. (Optional) Squeeze both sides of the included power cord anchor, insert the two ends into the two loops above the **Power In (10)** connector, then release the anchor so the two ends lock into the two loops. Position the anchor over the boot of the power cord connector, so that it cannot accidentally disconnect from the amplifier.
17. Flip the **Power Switch (1)** to the **On** position.
18. Plug in and power on your audio source device, then start audio playback.
19. Set the volume control on your preamplifier, television, or other audio source device to the maximum position.
20. Using a 1/8" flat head screwdriver, slowly turn the **Volume (5)** control clockwise until the volume level is at the loudest you would ever want it to be.

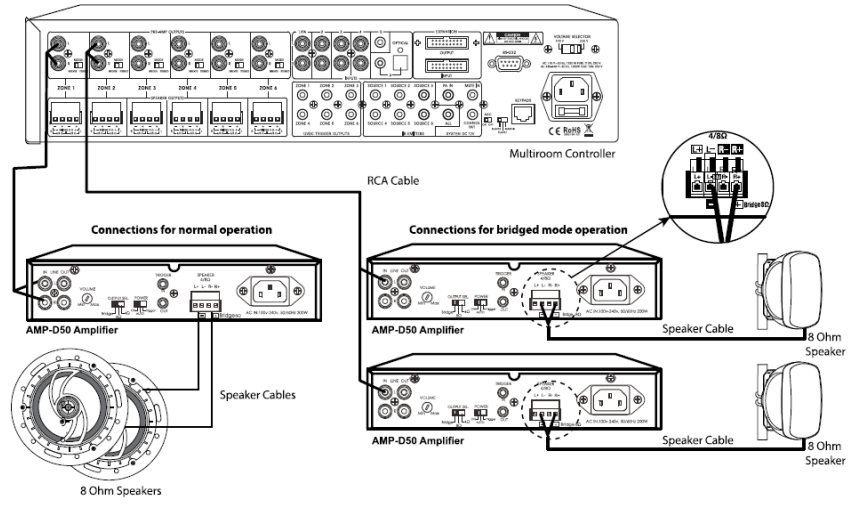

MONO BRIDGED INSTALLATION

Rather than driving two 8-ohm or 4-ohm speakers in stereo mode, the amplifier can be configured to bridge the two channels to provide 120 watts of power into a single 8-ohm load. *Note that only 8-ohm loads can be used when using Mono Bridged mode.*

1. Ensure that all equipment to be connected is powered off and unplugged from its power source prior to making any electrical or audio connections.
2. Place the amplifier in its intended location.
3. Using a 1/8" flat head screwdriver, loosen the **L-** and **R+** screws on the **Speaker (9)** Phoenix connector to open the speaker wire clamps.
4. Using a two-conductor speaker wire (not included), insert the negative lead into the **L- connector**, then tighten the screw to lock it in place. Give the wire a gentle tug to ensure it is securely attached to the connector. Repeat for the positive lead and the **R+ connector**.
5. Connect the negative lead of the speaker wire to the negative input on your speaker, then connect to the positive lead to the positive input.
6. Using a single conductor RCA cable (not included), plug one end into the **L connector** on the **Line In (3)**, then plug the other end into one of the analog stereo outputs on your preamplifier, television, or other audio source device.
7. (Optional) Using a second single-conductor RCA cable (not included), plug one end into one of the inputs on another amplifier, then plug the other end into the **L connector** on the **Line Out (4)**.
8. (Optional) Using a 3.5mm cable (not included), plug one end into the **Trigger In (8)** jack, then plug the other end into the trigger output of your controller.

9. (Optional) Using a 3.5mm cable (not included), plug one end into the trigger input of a device you want to control using the amplifier, then plug the other end into the **Trigger Out (8)**.
10. Set the **Output Selection (6)** switch to the Bridge position.
11. Set the **Power Selection (7)** switch to the **On**, **Auto**, or **Trigger** position, depending on how you want to control the amplifier's power-on behavior. When set to **On**, the amplifier is always on whenever the **Power Switch (1)** is in the **On** position. When set to **Auto**, the amplifier will power on when an audio signal is detected and will power off after a few minutes without an audio signal on the input. When set to the **Trigger** position, the amplifier turns on and off when a 12-volt signal is detected on the **Trigger In (8)**. When using the **Auto** or **Trigger** options, the **Power Switch (1)** on the front panel must be set to the **On** position.
12. Using a 1/8" flat head screwdriver, turn the **Volume (5)** control fully counterclockwise to the minimum position.
13. Ensure that the **Power Switch (1)** is in the **Off** position.
14. Plug the C13 connector on the included AC power cord into the C14 **Power In (10)** connector, then plug the other end into a nearby AC power outlet.
15. (Optional) Squeeze both sides of the included power cord anchor, insert the two ends into the two loops above the **Power In (10)** connector, then release the anchor so the two ends lock into the two loops. Position the anchor over the boot of the power cord connector, so that it cannot accidentally disconnect from the amplifier.
16. Flip the **Power Switch (1)** to the **On** position.
17. Plug in and power on your audio source device, then start audio playback.
18. Set the volume control on your preamplifier, television, or other audio source device to the maximum position.

19. Using a 1/8" flat head screwdriver, slowly turn the **Volume (5)** control clockwise until the volume level is at the loudest you would ever want it to be.

SPECIFICATIONS

Model	CT-250A
Audio Inputs	Stereo analog RCA
Audio Outputs	Buffered stereo analog RCA loop output
Output Power	50 watts/channel into 8 ohms with < 0.1% THD+N or 65 watts/channel into 4 ohms with < 0.1% THD+N or 120 watts into a single 8-ohm load with < 0.1% THD+N
Maximum Speaker Wire Size	12 AWG
Minimum Output Impedance	4 ohms in stereo mode 8 ohms in mono bridged mode
Trigger Input	12 VDC, 10 k Ω
Trigger Output	12 VDC, 100mA
Input Power	100 ~ 240 VAC, 50/60 Hz, 2.5A
Standby Power Consumption	\leq 0.5 watts
Dimensions	8.5" x 10.5" x 1.8" (216 x 267 x 45 mm)

REGULATORY COMPLIANCE

Notice for FCC



This device complies with Part 15 of the FCC rules. Operation is subject to the following two conditions: (1) this device may not cause harmful interference, and (2) this device must accept any interference received, including interference that may cause undesired operation.

Modifying the equipment without authorization may result in the equipment no longer complying with FCC requirements for Class B digital devices. In that event, your right to use the equipment may be limited by FCC regulations, and you may be required to correct any interference to radio or television communications at your own expense.

This equipment has been tested and found to comply with the limits for a Class B digital device, pursuant to Part 15 of the FCC Rules. These limits are designed to provide reasonable protection against harmful interference in a residential installation. This equipment generates, uses and can radiate radio frequency energy and, if not installed and used in accordance with the instructions, may cause harmful interference to radio communications. However, there is no guarantee that interference will not occur in a particular installation. If this equipment does cause harmful interference to radio or television reception, which can be determined by turning the equipment off and on, the user is encouraged to try to correct the interference by one or more of the following measures:

- Reorient or relocate the receiving antenna.
- Increase the separation between the equipment and receiver.
- Connect the equipment into an outlet on a circuit different from that to which the receiver is connected.
- Consult the dealer or an experienced radio/TV technician for help.

Notice for Industry Canada

This Class B digital apparatus complies with Canadian ICES-003.

Cet appareil numérique de la classe B est conforme à la norme NMB-003 du Canada.