

AMBIENT LIGHT SENSOR

XE range

The Nexmosphere XE range offers sensors that analyze and communicate environmental conditions. By detecting the surrounding circumstances, we enable the possibility to log and communicate these values, as well as actively respond to certain critical threshold levels such as high temperature.



Ambient light sensor

The XE- Ambient light sensor detects the amount of light in its surroundings and communicates the amount of lux back to the Xperience controller, facilitating adjustment of lighting levels based on environmental light conditions.

Features

- Detects 1-120.000 lux
- Multiple trigger modes
- Multiple trigger range mappings

X-talk

The XE Ambient light sensor can easily be connected to any of the Nexmosphere Xperience controllers using the X-talk interface. All settings of the XE sensor are programmable on the Controller, enabling a seamless integration in your application.

- Plug and smile interface
- Compatible with any Nexmosphere Xperience controller
- Powered by and configurable with Nexmosphere Xperience controller

Ambient light sensor

The ambient light sensor measures the amount of lux in a specific room or outdoor environment. This enables real-time adjustments of Digital Signage installations to the current light conditions such as display brightness adjustment or showing different content during night and daytime.

The sensor can provide the measured lux values on request, as well as send a trigger when the lux value is within a specific range.

- 1-120.000 lux
- Auto trigger when lux value is within a specific range
- Multiple range mappings available (e.g. outdoor, office etc)

Benefits

- Unique cable connection (bottom feed or side feed) enables invisible cable installation
- Securely mounts on any flat surface, horizontal, vertical or angled
- Easy removable non-marking double-sided tape
- Status LED for visual feedback



XZ-AMBIENT LIGHT SENSOR

Mounting specifications

Mount the sensor in such a way that the ambient light will reach the curved top side of the sensor.

Thermal specifications

Operating temperature: +10°C...+40°C/ +50°F ... +104°F
Storage temperature: -20°C...+50°C/ -4°F ... +122°F

Electrical specifications

- Operating voltage: 5V DC (via X-talk interface)
- Power consumption: 50mA

Miscellaneous

- Custom cable lengths available on request (MOQ 50pcs)
- 1-year warranty (optional 3-year extended warranty available)

Packaging

Items per carton 1, 10 or 50 pcs

Standards and Certifications



RoHS
compliant

Mechanical dimensions

LxWxH: 29 x 22 x 10 mm
Fixation: Double-sided adhesive tape

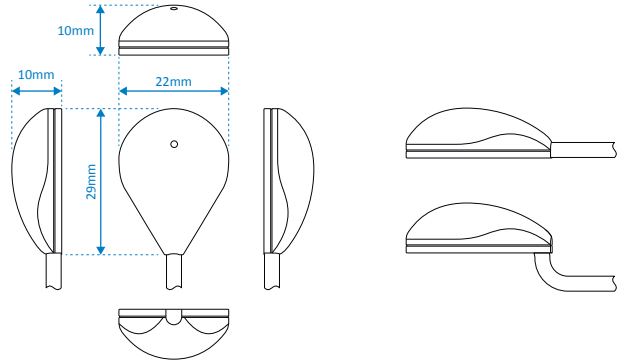

Ordering information

Product ID	Description	Netto weight	Quantity
XE-A20	Ambient light sensor, 180cm cable, white	20g	1 pc

Nexmosphere

High Tech Campus 10 (Mμ building)
5656 AE Eindhoven • The Netherlands

T +31 40 240 7070
E sales@nexmosphere.com

© 2020 Nexmosphere. All rights reserved. v1.0 / 02-20
All content contained herein is subject to change without prior notice.