

LIGHT SENSOR

XZ range

The Nexmosphere XZ range offers a variety of sensors that detect a certain status of objects they are in contact with. By detecting the object status, we enable the possibility to log and communicate these values, as well as actively respond to critical threshold values.



Light sensor

The XZ- Light sensor can detect the amount of light that falls in the sensor. This information can be used to determine whether merchandise is placed on top of the sensor or not, to create Lift & Learn or Place & Learn applications whenever RFID or battery-powered sensors can't be applied.

Features

- Pick-up detection using light sensor
- Adjustable trigger values
- Auto-calibration to environment (light sensitivity)

X-talk

The XZ Light sensor can easily be connected to any of the Nexmosphere Xperience controllers using the X-talk interface. All settings of the XZ sensor are programmable on the controller, enabling a seamless integration in your application.

- Plug and smile interface
- Compatible with any Nexmosphere Xperience controller
- Powered by and configurable with Nexmosphere Xperience controller

Pick-up detection with light sensor

By placing a light sensor below a small hole on which merchandise is placed, the pick-up or place-back of a product can be detected. The XZ- Light sensor is designed to make this application as simple as possible, in any light conditions, no matter what type of merchandise you are using.

- Adjustable trigger values
- Auto-calibration to environment
- Adjustable light sensitivity

Benefits

- Unique cable connection (bottom feed or side feed) enables invisible cable installation
- Securely mounts on any flat surface, horizontal, vertical or angled
- Easy removable non-marking double sided tape
- Status LED for visual feedback



XZ-LIGHT SENSOR

Mounting specifications

Mount the bottom side of the sensor (flat part), centered under a small circular cutout in the top panel on which the merchandise is displayed. (see example on the right)

Thermal specifications

Operating temperature: +10°C...+40°C/ +50°F ... +104°F
 Storage temperature: -20°C...+50°C/ -4°F ... +122°F

Electrical specifications

- Operating voltage: 5V DC (via X-talk interface)
- Power consumption: 50mA

Miscellaneous

- Custom colors and cable lengths available on request (MOQ 50pcs)
- 1-year warranty (optional 3-year extended warranty available)

Packaging

Items per carton 1, 10 or 50 pcs

Standards and Certifications



RoHS
compliant

Mechanical dimensions

LxWxH: 29 x 22 x 10 mm
 Fixation: Double sided adhesive tape

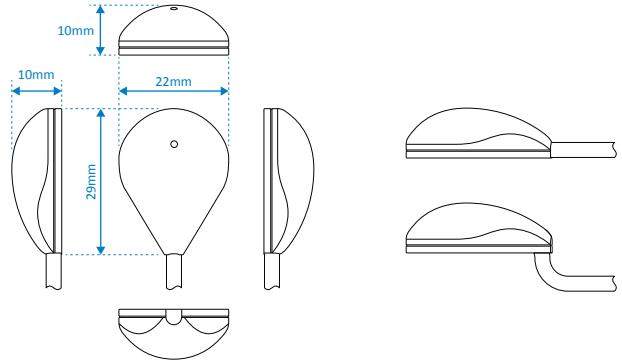

Sensor placement (bottom/flat side of product)

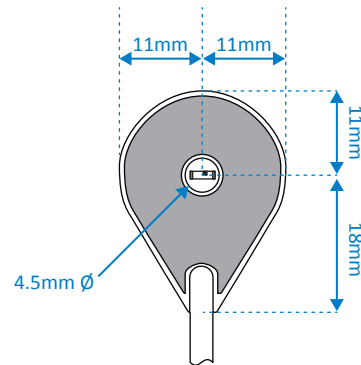

Mounting example

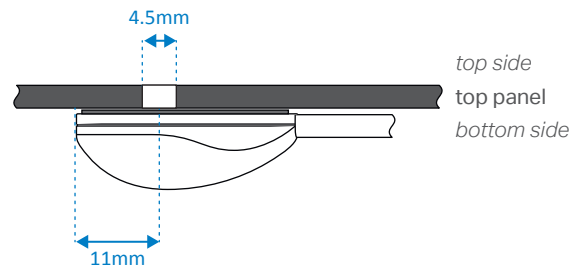

Ordering information

Product ID	Description	Netto weight	Quantity
XZ-L20	X-Dot Light sensor, 180cm cable, white	20g	1 pc

Nexmosphere

High Tech Campus 10 (Mμ building)
 5656 AE Eindhoven • The Netherlands

T +31 40 240 7070
 E sales@nexmosphere.com

© 2020 Nexmosphere. All rights reserved. v1.0 / 02-20
 All content contained herein is subject to change without prior notice.